

# 精良设备 SUPERIOR EQUIPMENT



35KV变电站 35KV converting station



XM-270 密炼机 XM-270 internal mixer



内胎生产线 Inner tube production line



滤胶生产线 Production line for rubber filtration



冷喂料挤出机 cold feed extruder



轮胎胶囊硫化机 Tire bladder curing machinery

# 轮胎硫化胶囊 TYRE CURING BLADDER

## 使用说明 INSTRUCTIONS

轮胎硫化胶囊（以下简称胶囊）是现代轮胎生产中硫化工序的必要工具。胶囊质量的优劣，不但与生产成本密切相关，而且对轮胎的质量有着重大的影响。为了延长胶囊的使用寿命，减少不必要的损失，望您在胶囊安装使用之前，仔细阅读本说明，并按说明中的要求检验、存储和使用胶囊。

### 胶囊的检验

1. 胶囊入库时，请检验胶囊的包装是否完整，规格等标识是否清晰，如有疑问请立即与我们联系。
2. 请按照我们提供的《轮胎硫化胶囊》标准（Q/JTD001-2003）或供货合同的要求，对产品进行检验。
3. 打开产品包装袋或包装箱，每条产品应附有一张《BLADDER使用记录》表。
4. 不符合您要求的产品，请您为我们暂时妥善保管，并及时与我们联系，以便为您提供更快更好地服务。

### 胶囊的存储条件

5. 产品包装后码放高度小于2500mm。以使其在较长期的存放过程中，产品和包装物不致变形过度，影响其使用。
6. 胶囊应存储在室温、蔽光、无化学药品、远离热源1000mm以上的环境中。特别要注意不能和各类油品接触。
7. 在使用48小时前，最好不要开箱，以免与第6条存储条件不符。
8. 工程胎胶囊必须恢复到原始形状存放。
9. 胶囊的存储和搬运中，应注意避免与尖锐的物体相接触，以防损伤胶囊。

### 胶囊的使用建议

10. 建议胶囊从生产日期到使用前的停放时间应不少于90天。
11. 胶囊在使用前的24小时，打开包装并尽量使其恢复原状。
12. 在安装前应核对胶囊的型号和所硫化外胎的型号是否匹配，并建议您使用说明书中推荐的与胶囊型号相适应的卡盘尺寸。
13. 您在安装胶囊紧固卡具的过程中，建议您不要使用润滑类的油脂，以免对胶囊内部造成损伤。如果您安装操作时一定要提高某些部件的润滑性能，请您尽量少的使用一些稀释后的水溶性硅乳液，并注意使其不要滴落在轮胎模具上。
14. 进行气密性检验时，伸张要适量，以免损坏胶囊或产生其它问题。
15. 除氧严格的过热水和氮气硫化会明显延长胶囊的使用寿命。
16. 良好的胎坯内喷涂有利于轮胎和胶囊的分离和延长胶囊使用寿命。
17. 在胶囊投入使用后，请您认真填写好《BLADDER使用记录》表，以便发生产品质量问题时获得更好的服务。

The tyre curing bladder (hereinafter referred to as bladder) is an essential tool in curing tyres. The quality of the bladder is closely related not only to the production cost but also to the quality of the tyre. In order to extend the bladder service life and avoid unnecessary losses, please refer to instructions carefully.

### Pre-storage inspection

1. Please check whether the package is complete and the bladder size is clearly identified before storage.
2. Please inspect the bladder according to the "Tyre Curing Bladder Standard" (Q/JTD001-2003) we have provided or according to the contract requirement.
3. Each bladder is attached with a Bladder Performance Record Form in each bag or each case.
4. If you find the goods do not meet your requirements, please keep them as they are and contact us immediately so that we can provide faster and better service for you.

### Storage Conditions

5. In order to avoid possible deformation during long-time storage, the height for bagged bladders must not exceed 6 layers or 2500mm.
6. Store the bladders under room temperature, keep them away from chemicals and heat sources, prevent them from sunlight, and what's more, bladders must be kept away from any oil.
7. It is better not to open the case 48 hours before use in case the storage conditions are in conflict with the above article 6.
8. The OTR bladder must be resumed to its original shape before being put in storage.
9. Please take care to prevent bladders from any sharp objects to avoid any possible hard damages under storage and transportation conditions.

### Proposals

10. We suggest that you store the bladder at least 90 days from the date of production before use.
11. Please resume the bladder to its original shape 24 hours prior to use.
12. Before mounting bladders, please check whether the bladders size match as the tire size. We suggest you choosing the proper clamping size as per bladder clamping parameters.
13. We suggest you do not use any lubricants during clamping the bladders, please pay attention not to use any diluted water-solubility silicon latex and not to drop it on the tyre mould surface.
14. When you test the bladder air tightness, the elongation of bladders should be proper in order to avoid destroying the bladder or causing other problems.
15. The strict deoxidization and nitrogen curing can evidently extend the bladder life.
16. Even spraying of isolation agent inside the green tyres is necessary in order to extend the bladder service life.
17. Please fill in the Bladder Performance Record Form seriously.

## 花纹类型 VENTS/ETCHING TYPE



## 注射A型子午胎硫化胶囊

### INJECTION A TYPE RADIAL TYRE CURING BLADDER

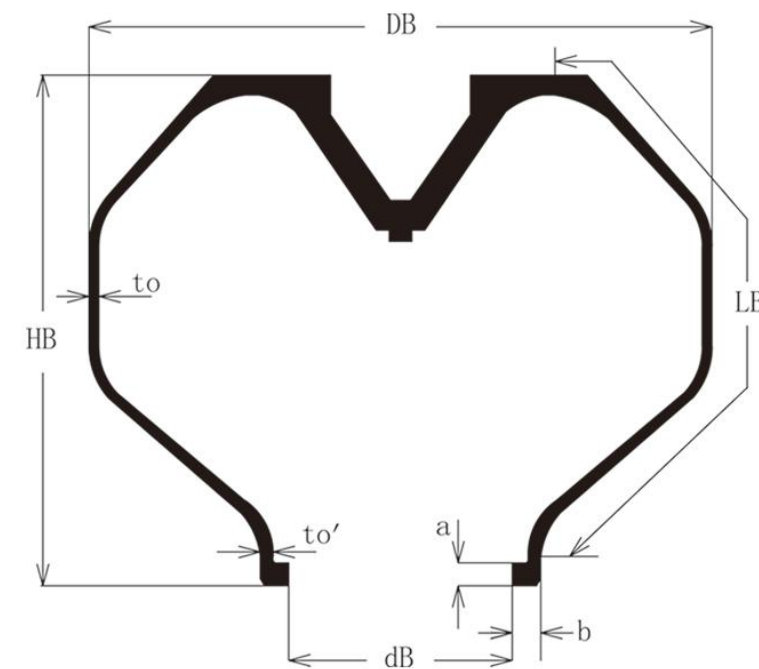

胶囊代号	适用轮胎规格	花纹类型	胶囊尺寸					胶囊安装尺寸		
			断面周长LB (mm)	外直径DB (mm)	总高度HB (mm)	冠部厚度to (mm)	颈部厚度to' (mm)	夹缘内径dB (mm)	夹缘高度a (mm)	夹缘宽度b (mm)
Bladder code	Applied Tyre section	Vents/ Etching Type	Effective Periphery LB(mm)	Outside Diameter DB(mm)	Overall Height HB(mm)	Crown Gauge to(mm)	Neck Gauge to'(mm)	Foot ID. dB(mm)	Foot Height a(mm)	Foot Width b(mm)
A12" × 215 × 500		麻面	460	500	290	4.5	9.0	300	14.5	15.0
A12" × 243 × 515		麻面	416	535	310	4.5	9.0	300	14.5	15.0
A12" × 250 × 565		麻面	484	565	320	4.8	9.0	300	14.5	15.0
A14" × 270 × 530-1		麻面	475	530	330	4.8	8.5	329	15.0	15.5
A14" × 270 × 530-2		麻面	475	530	330	4.8	8.5	329	15.0	15.5
A14" × 300 × 550-1		麻面	509	550	350	4.8	8.5	329	15.0	15.5
A14" × 300 × 550-2		麻面	509	550	350	4.8	8.5	329	15.0	15.5

## 注射B型子午胎硫化胶囊

### INJECTION B TYPE RADIAL TYRE CURING BLADDER

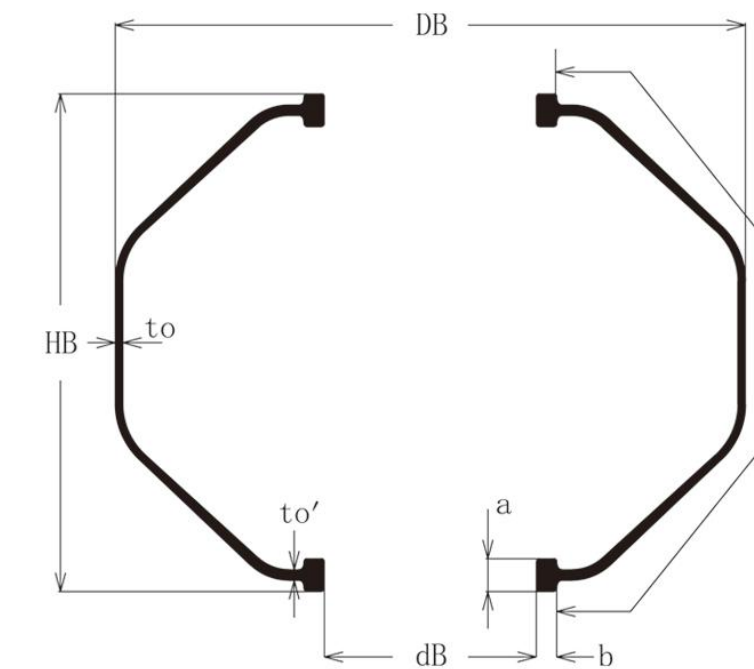

胶囊代号	适用轮胎规格	花纹类型	胶囊尺寸					胶囊安装尺寸		
			断面周长LB (mm)	外直径DB (mm)	总高度HB (mm)	冠部厚度to (mm)	颈部厚度to' (mm)	夹缘内径dB (mm)	夹缘高度a (mm)	夹缘宽度b (mm)
Bladder code	Applied Tyre section	Vents/ Etching Type	Effective Periphery LB(mm)	Outside Diameter DB(mm)	Overall Height HB(mm)	Crown Gauge to(mm)	Neck Gauge to'(mm)	Foot ID. dB(mm)	Foot Height a(mm)	Foot Width b(mm)
B145R12-2		碎石	332	450	228	5.2	7.0	224	21.0	12.0
B145R12-3		碎石	334	465	235	5.0	7.5	224	21.0	13
B155R12-1	145/70R12、155/55R12	碎石	310	408	240	5.0	7.0	224	21.0	12
B155R13-2	155/70R13	碎石	350	430	274	5.0	8.0	224	23.0	12
B155R13-3	155/65R13	碎石	330	440	250	5.0	7.5	234	21.0	12.0
B165R13-3	145/175R13	碎石	316	440	235	4.0	7.5	234	21.0	12.0
B165R13-4	165/70R13	碎石	364	450	281	4.0	7.5	234	21.0	12
B165R13-4(2)	165/70R13	碎石	364	450	281	5.0	7.5	234	21.0	12
B175R13-2	165/75R13、175/75 (70) R13、185/70R13	碎石	380	460	300	4.0	10.0	234	21.0	12.0
B175R13-2(2)	165/75R13、175/75 (70) R13、185/70R14	碎石	380	460	300	5.0	10.0	234	21.0	12.0
B175R13-3	155R13LT/165(175) /70R13	碎石	376	460	286	4.5	7.0	224	21.0	12.5
B175R13-3(2)	155R13LT/165(175) /70R13	麻面	376	460	286	4.5	7.0	224	21.0	12.5
B185R14-2	195/60R14、185/60R14 195/50R15	碎石	380	430	316	4.8	9.6	260	21.4	11.7
B185R14-3	155/195R14	碎石	338	460	256	4.5	10.0	260	21.0	12.0
B185R14-4		碎石	400	460	312	4.5	8.0	224	23.0	12.5
B185R14-5		碎石	410	490	316	5.0	7.0	248	23.0	12.0

### 注射B型子午胎硫化胶囊

#### INJECTION B TYPE RADIAL TYRE CURING BLADDER

胶囊代号	适用轮胎规格	花纹类型	胶囊尺寸					胶囊安装尺寸		
			断面周长LB (mm)	外直径DB (mm)	总高度HB (mm)	冠部厚度to (mm)	颈部厚度to' (mm)	夹缘内径dB (mm)	夹缘高度a (mm)	夹缘宽度b (mm)
Bladder code	Applied Tyre section	Vents/ Etching Type	Effective Periphery LB(mm)	Outside Diameter DB(mm)	Overall Height HB(mm)	Crown Gauge to(mm)	Neck Gauge to'(mm)	Foot ID. dB(mm)	Foot Height a(mm)	Foot Width b(mm)
B195R14-1	185/195/60R14	碎石	370	460	294	4.5	9.5	250	22.0	13.0
B195R14-2		碎石	420	480	320	4.5	8.0	224	23.0	12.5
B205R14-2	165/205R14/15	碎石	375	490	276	5.0	7.0	248	21.0	12.0
B205R14-2(2)	165/205R14/15	麻面	375	490	276	5.0	7.0	248	21.0	12.0
B205R14-3	205/70(75/80)R14	碎石	442	510	342	4.0	7.0	248	21.0	12.0
JTB14-S-390	185/70R14	碎石	415	478	308	5.5	8.4	248	22.0	14.0
JTB1651		碎石	389	485	270	5.0	7.3	248	21.0	12.0
BR14-1		碎石	374	470	266	5.0	9.5	250	22.0	13
RB14-2		碎石	420	520	300	4.2	9.5	250	22.0	12.0
RB14-2(2)		碎石	420	520	300	5.0	9.5	250	22.0	12.0
B10×250×460		碎石	331	460	250	5.3	9.0	250	22.0	14.0
B10×270×460		碎石	351	460	270	5.3	9.0	250	22.0	14.0
B10×270×410		碎石	315	410	270	4.8	9.0	250	22.0	14.0
B10"×300×470-1		碎石	388	470	300	5.3	9.0	250	22.0	14.0
B10"×300×470-2		碎石	388	470	300	4.8	9.0	250	22.0	14.0
B10"×350×470-1		碎石	438	470	350	5.3	9.0	250	22.0	14.0
B10"×350×470-2		碎石	438	470	350	4.8	9.0	250	22.0	14.0
B14×310×560		碎石	390	560	310	5.0	9.0	350	22.0	14.0
B14×350×560		碎石	430	560	350	5.3	9.0	350	22.0	14.0
B14×350×560-2		碎石	430	560	350	5.3	9.0	350	22.0	14.0
B14×340×610		碎石	443	610	340	5.0	9.0	350	22.0	14.0
B14×370×610		碎石	473	610	370	5.0	9.0	350	22.0	14.0
B14×400×610		碎石	503	610	400	5.0	9.0	350	22.0	14.0

### 注射B型子午胎硫化胶囊

#### INJECTION B TYPE RADIAL TYRE CURING BLADDER

胶囊代号	适用轮胎规格	花纹类型	胶囊尺寸					胶囊安装尺寸		
			断面周长LB (mm)	外直径DB (mm)	总高度HB (mm)	冠部厚度to (mm)	颈部厚度to' (mm)	夹缘内径dB (mm)	夹缘高度a (mm)	夹缘宽度b (mm)
Bladder code	Applied Tyre section	Vents/ Etching Type	Effective Periphery LB(mm)	Outside Diameter DB(mm)	Overall Height HB(mm)	Crown Gauge to(mm)	Neck Gauge to'(mm)	Foot ID. dB(mm)	Foot Height a(mm)	Foot Width b(mm)
B14×340×610-2		碎石	443	610	340	5.0	9.0	350	22.0	14.0
B14×370×610-2		碎石	473	610	370	5.0	9.0	350	22.0	14.0
B14×400×610-2		碎石	503	610	400	5.0	9.0	350	22.0	14.0
B15×300×600		碎石	402	600	300	5.0	9.0	375	22.0	14.0
B15×350×600		碎石	452	600	350	4.5	9.0	375	22.0	14.0
B15×350×620		碎石	463	620	350	4.5	9.0	375	22.0	14.0
P408		碎石	394	495	316	6.4	9.5	286	21.4	11.6
P350		碎石	324	444	228	4.0	9.5	235	23.0	11.7
P327		碎石	311	406	203	4.0	9.5	197	21.4	11.7
P420		碎石	400	508	342	6.4	9.5	311	21.4	11.6
B155R15-1 (2)	155R15	麻面	364	508	266	5.0	9.6	285.7	21.4	11.7
B195R15-1		碎石	344	450	278	5.0	10.0	285	21	11.7
B195R15-2		碎石	413	490	345	5.0	7.0	277	21.0	13.0
B205R15-1	195/65R15、 205/60(70/75)R15	碎石	420	546	305	4.2	9.0	277	21.0	13.0
B205R15-1(2)	195/65R15、 205/60(70/75)R15	碎石	420	546	305	6.0	9.0	277	21.0	13.0
B225R15-2	235/75R15	碎石	508	576	367	4.5	7.0	277	21.0	13.0
B185R16-3	185/215R15/16	碎石	435	550	325	5.0	7.0	277	21.0	13.0
B205R16-3	195/65R15 205/55R16	碎石	416	508	322	4.1	9.6	285.7	21.4	11.7
B215R16-1		碎石	426	500	356	5.0	7.0	300	22.00	12.00
B235R16-2		碎石	518	588	408	4.5	10.0	299	22.0	13.7

### 注射B型子午胎硫化胶囊

#### INJECTION B TYPE RADIAL TYRE CURING BLADDER

胶囊代号	适用轮胎规格	花纹类型	胶囊尺寸					胶囊安装尺寸		
			断面周长LB (mm)	外直径DB (mm)	总高度HB (mm)	冠部厚度to (mm)	颈部厚度to' (mm)	夹缘内径dB (mm)	夹缘高度a (mm)	夹缘宽度b (mm)
Bladder code	Applied Tyre section	Vents/ Etching Type	Effective Periphery LB(mm)	Outside Diameter DB(mm)	Overall Height HB(mm)	Crown Gauge to(mm)	Neck Gauge to'(mm)	Foot ID. dB(mm)	Foot Height a(mm)	Foot Width b(mm)
B235R16-2(2)		碎石	518	588	408	5.0	10.0	299	22.0	13.7
B235R16-3		麻面	552	590	404	5.0	7.0	277	21.0	13.0
B225R16-1	225R16	碎石	480	588	360	5.0	7.0	299	22.0	13.0
B225R16-1(2)	225R16	碎石	480	588	360	5.0	7.0	299	22.0	13.0
B225R16-1(3)	225R16	碎石	480	588	360	6.0	7.0	299	22.0	13.0
B225R16-1(4)	225R16	麻面	480	588	360	5.0	7.0	299	22.0	13.0
B225R16-2		碎石	464	540	360	4.0	8.5	272	22.0	12.7
B225R16-2(2)		碎石	464	540	360	5.0	8.5	272	22.0	12.7
B650R16-1	650R16、7.00R16、225/60R16、215 (205/195) /65R15	碎石	485	545	370	6.0	9.5	250	22.0	13.0
B650R16-2	650R16、7.00R16、225/60R16、215 (205/195) /65R15	麻面	485	545	370	6.0	9.5	250	22.0	13.0
B825R16-2	8.25R16	麻面	550	600	440	6.0	10.0	300	24.0	12.0
B825R16-3	8.25R16	碎石	550	600	440	6.0	10.0	300	24.0	12.0
B825R16-4	8.25R16	麻面	562	650	428	6.0	10.0	300	24.0	12.0
B345R16-1		碎石	760	790	500	6.0	10.0	300	24.0	12.0
B368-D		麻面	420	448.6	363.6	5.2	10.0	276	20.5	14.2
B368-D		麻面	420	448.6	363.6	5.2	10.0	276	20.5	14.2
B518-D		碎石	372	406	323.5	5.2	9.0	276	20.5	14.2
B518-D		碎石	372	406	323.5	5.2	9.0	276	20.5	14.2
PBR005		碎石	390	490	300	4.5	6.5	276	23	12.5
PBR007		碎石	440	520	300	4.5	6.5	276	23	12.5
JY0145		碎石	370	476	298	4.5	8.0	300	25	14.2

### 注射B型子午胎硫化胶囊

#### INJECTION B TYPE RADIAL TYRE CURING BLADDER

胶囊代号	适用轮胎规格	花纹类型	胶囊尺寸					胶囊安装尺寸		
			断面周长LB (mm)	外直径DB (mm)	总高度HB (mm)	冠部厚度to (mm)	颈部厚度to' (mm)	夹缘内径dB (mm)	夹缘高度a (mm)	夹缘宽度b (mm)
Bladder code	Applied Tyre section	Vents/ Etching Type	Effective Periphery LB(mm)	Outside Diameter DB(mm)	Overall Height HB(mm)	Crown Gauge to(mm)	Neck Gauge to'(mm)	Foot ID. dB(mm)	Foot Height a(mm)	Foot Width b(mm)
JY1545		碎石	484	580		4.5	8.0	300	25	14.2
JY1545-2		碎石	514	580	408	4.5	8.0	300	25	14.2
JY1145		碎石	406	525	270	4.5	10	300	25	14.2
JS1045		碎石	448	560	294	4.5	10	300	25	14.2
RB1601		碎石	460	590	346	6.0	8	310	21	12
RB16-3		碎石	370	480	308	5.5	8.0	310	21.0	12.0
RBSC1604		碎石	394	498	326	4.5	8.0	310	21.0	12.0
RBSC1605		碎石	440	536	370	4.5	8.0	310	21.0	12.0
RB16-10		碎石	346	460	296	5.5	8.0	310	21.0	12.0
16-J-490	7.50R16/ 8.25R16	麻面	497	600	385	4.5	13.0	310	25.0	13.0
B750R16-1	7.50R16	碎石	497	600	385	6.0	13.0	310	25.0	13.0
B750R16-2	7.50R16	麻面	497	600	385	6.0	13.0	310	25.0	13.0
16-J-540	8.25R16	麻面	544	650	414	4.5	13.0	310	25.0	13.0
B205R17-1	205/45(50)R17 225/45R17	碎石	372	500	320	4.5	9.6	336.5	21.4	11.7
B205R17-1(2)	205/45(50)R17 225/45R17	碎石	372	500	320	6.3	9.6	336.5	21.4	11.7
B205R17-1(3)	205/45(50)R17 225/45R17	麻面	372	500	320	6.3	9.6	336.5	21.4	11.7
B205R17-2	205/40R17	碎石	338	470	300	4.5	8.0	336.5	24.0	12.0
B205R17-2(2)	205/40R17	碎石	338	470	300	4.5	8.0	336.5	24.0	12.0
B205R17-3		碎石	326	470	288	5.0	8.0	336.5	24.0	12.0

### 注射B型子午胎硫化胶囊

#### INJECTION B TYPE RADIAL TYRE CURING BLADDER

胶囊代号	适用轮胎规格	花纹类型	胶囊尺寸					胶囊安装尺寸		
			断面周长LB (mm)	外直径DB (mm)	总高度HB (mm)	冠部厚度to (mm)	颈部厚度to' (mm)	夹缘内径dB (mm)	夹缘高度a (mm)	夹缘宽度b (mm)
Bladder code	Applied Tyre section	Vents/ Etching Type	Effective Periphery LB(mm)	Outside Diameter DB(mm)	Overall Height HB(mm)	Crown Gauge to(mm)	Neck Gauge to'(mm)	Foot ID. dB(mm)	Foot Height a(mm)	Foot Width b(mm)
B215R17-1		碎石	382	500	330	4.5	9.6	336.5	21.4	11.7
17-j-380		网格	398	520	338	4.5	11	334	24.8	13.4/11.9
B225R17-1(4)	225/55R18	碎石	427	520.7	366	4.5	9.551	336.55	21.88	11.66
B235R17-1		碎石	392	516	330	4.5	9.6	336.5	21.88	11.66
B235R17-2		碎石	500	610	398	4.5	9.6	336.5	21.88	11.66
B255R17-1		碎石	460	540.7	398	4.5	9.6	336.5	21.4	11.7
B255R17-1(2)		碎石	460	540.7	398	5.5	9.6	336.5	21.4	11.7
B265R17-1		碎石	520	620	412	4.5	9.5	336	21.00	12.00
B265R17-2		碎石	570	620	462	4.5	9.5	336	21.00	12.00
DP396		碎石	425	590	315	4.1	9.5	336	21.88	11.66
B235R17.5-1		麻面	506	590	406	6.0	11.0	300	26.0	14.0
18-J-378		麻面	393	530	340	4.0	11.0	360	24.8	13.2
B235R18-2	235/50(60、55) R18	碎石	432	572	356	4.5	9.6	360	21.88	11.66
B235R18-2(2)		碎石	462	572	386	4.5	9.6	360	21.88	11.66
B235R18-2(3)	235/50(60、55) R18	碎石	432	572	356	5.5	9.6	360	21.88	11.66
B235R18-2(4)	235/50(60、55) R18	碎石	432	572	356	4.5	9.6	360	21.88	11.66
18A		碎石	372	496	326	6.0	8.0	356	23.0	12.0
18B		碎石	337	480	296	6.0	8.0	356	23.0	12.0
18H		碎石	550	640	441	5.0	8.0	356	23.0	12.0
B215R19-2		碎石	334	500	288	5.0	7.0	380	24	12.7
B235R19-1		碎石	360	500	314	5.0	7.0	380	24	12.7
B245R19-1	235/55R19、245/45(55)R19	碎石	458	562	400	4.5	9.6	387	21.88	11.66
B245R19-2		碎石	380	520	334	4.2	7.0	380	24.00	12.70

### 注射B型子午胎硫化胶囊

#### INJECTION B TYPE RADIAL TYRE CURING BLADDER

胶囊代号	适用轮胎规格	花纹类型	胶囊尺寸					胶囊安装尺寸		
			断面周长LB (mm)	外直径DB (mm)	总高度HB (mm)	冠部厚度to (mm)	颈部厚度to' (mm)	夹缘内径dB (mm)	夹缘高度a (mm)	夹缘宽度b (mm)
Bladder code	Applied Tyre section	Vents/ Etching Type	Effective Periphery LB(mm)	Outside Diameter DB(mm)	Overall Height HB(mm)	Crown Gauge to(mm)	Neck Gauge to'(mm)	Foot ID. dB(mm)	Foot Height a(mm)	Foot Width b(mm)
B265R19-1		碎石	473	584	402	4.5	9.6	387	21.88	11.66
B245R19.5-2		麻面	530	650	414	6.0	11.0	340	26.0	13.0
B265R195-1		碎石	569	660	440	6.0	12.0	340	26.00	13.00
B265R195-2		麻面	569	660	440	6.0	12.0	340	26.00	13.00
B435R195-1		麻面	775	720	628	6.0	12.0	340	26.0	13.0
B445R195-1		麻面	744	690	608	6.0	12.0	340	26.0	13.0
B245R20-1		碎石	404	570	346	4.5	8	396	24	12.5
B245R20-1(2)		碎石	404	570	346	6.0	8	396	24	12.5
B255R20-1		碎石	490	600	426	4.5	8	396	24	12.5
B255R20-1(2)		碎石	490	600	426	6.0	8	396	24	12.5
B275R20-1		碎石	460	600	402	4.5	8	403	24	12.7
B285R20-1		麻面	440	540	402	6.0	8.0	403	24.0	12.7
B285R20-2		麻面	510	634	440	5.5	8.0	403	24.0	12.7
B900R20-3	9.00R20	麻面	632	760	490	8.0	12.0	380	26.0	14.0
B1000R20-3	9.00/10.00R20	碎石	651	815	468	7.8	12.0	380	26.0	14.0
B1000R20-3(9)	9.00/10.00R20	碎石	651	815	468	7.8	12.0	380	26.0	14.0
B1000R20-3(10)	9.00/10.00R20	碎石	651	815	468	7.8	12.0	380	26.0	14.0
B1000R20-4	9.00/10.00R20	麻面	651	815	468	7.8	12.0	380	26.0	14.0
B1000R20-4(5)	9.00/10.00R20	麻面	651	815	468	7.8	12.0	380	26.0	14.0
B1000R20-4(6)	9.00/10.00R20	麻面	651	815	468	7.8	12.0	380	28.0	14.0
B1000R20-11	10.00/11.0R20	麻面	670	830	480	8.0	12.0	380	26.0	14.0
B10-237A	9.00/10.00R20	麻面	670	815	475	7.8	15.5	360	28.0	15.5
B10-237A		麻面	692	830	474	8.0	15.5	360	28.0	15.5

### 注射B型子午胎硫化胶囊

#### INJECTION B TYPE RADIAL TYRE CURING BLADDER

胶囊代号	适用轮胎规格	花纹类型	胶囊尺寸					胶囊安装尺寸		
			断面周长LB (mm)	外直径DB (mm)	总高度HB (mm)	冠部厚度to (mm)	颈部厚度to' (mm)	夹缘内径dB (mm)	夹缘高度a (mm)	夹缘宽度b (mm)
Bladder code	Applied Tyre section	Vents/ Etching Type	Effective Periphery LB(mm)	Outside Diameter DB(mm)	Overall Height HB(mm)	Crown Gauge to(mm)	Neck Gauge to'(mm)	Foot ID. dB(mm)	Foot Height a(mm)	Foot Width b(mm)
20-J-650	10.00/11.00R20	麻面	650	780	506	6.5	12.7	384.2	28.4	12.7
B411-C		麻面	732	737	626	8.5	12.5	384	26.5	13.0
B1100R20-1	9.00/10.00/11.00R20	碎石	670	830	442	9.0	13.0	380	26.0	14.0
B11-272A	9.00/10.00/11.00R20	麻面	762	830	544	8.0	15.5	360	28.0	15.5
B1100R20-3	11.00R20	麻面	688	830	480	7.8	13.0	380	26.0	14.0
B1100R20-3(G)	11.00R20	麻面	688	830	480	7.8	13.0	380	27.0	14.0
B1100R20-3(3)		麻面	688	830	480	9.0	13.0	380	26.0	14.0
20-J-680	11.00R20	麻面	696	830	496	6.8	12.7	384.2	28.4	12.7
B1200R20-3	11.00/12.00R20	碎石	740	865	516	7.8	12.0	380	26.0	14.0
B1200R20-3(2)	11.00/12.00R20	碎石	740	865	516	7.8	12.0	380	26.0	14.0
B1200R20-3(9)	11.00/12.00R20	碎石	740	865	516	7.8	12.0	380	26.0	14.0
B1200R20-3(10)	11.00/12.00R20	碎石	740	865	516	7.8	12.0	380	26.0	14.0
B1200R20-4	11.00/12.00R20	麻面	740	865	516	7.8	12.0	380	26.0	14.0
B1200R20-4(5)	11.00/12.00R20	麻面	740	865	516	7.8	12.0	380	26.0	14.0
B1200R20-4(6)	11.00/12.00R20	麻面	740	865	516	7.8	12.0	380	28.0	14.0
B1200R20-4(7)	11.00/12.00R20	麻面	740	865	516	7.8	12.0	380	26.0	14.0
B1200R20-13	11.00/12.00R20	麻面	740	865	516	7.8	12.0	380	26.0	14.0
B1400R20-2	1400R20/385 (425)	碎石	840	830	684	8.0	12.0	380	24.0	14.0
B1400R20-3	1400R20	麻面	822	920	586	8.0	12.0	380	24.0	14.0
B305R22-1		碎石	500	656	440	4.5	8	454	24	12.7
B305R22-1(2)		碎石	500	656	440	6.0	8	454	24	12.7
20A522R		麻面	522	720	381	6.0	15.5	410	28.0	15.5
B225-170A		麻面	487	740	340	8.5	15.5	412	28.0	15.0

### 注射B型子午胎硫化胶囊

#### INJECTION B TYPE RADIAL TYRE CURING BLADDER

胶囊代号	适用轮胎规格	花纹类型	胶囊尺寸					胶囊安装尺寸		
			断面周长LB (mm)	外直径DB (mm)	总高度HB (mm)	冠部厚度to (mm)	颈部厚度to' (mm)	夹缘内径dB (mm)	夹缘高度a (mm)	夹缘宽度b (mm)
Bladder code	Applied Tyre section	Vents/ Etching Type	Effective Periphery LB(mm)	Outside Diameter DB(mm)	Overall Height HB(mm)	Crown Gauge to(mm)	Neck Gauge to'(mm)	Foot ID. dB(mm)	Foot Height a(mm)	Foot Width b(mm)
R225-630A		麻面	652	812	480	8.0	15.5	412	28.0	15.0
B315R22.5-1	315/80R22.5	麻面	710	830	534	8.0	15.5	412	28.0	15.0
B315R22.5-2	315/80R22.5	麻面	710	830	534	8.0	15.5	412	29.0	15.0
B315R22.5-3	315/80R22.5	麻面	710	830	548	8.0	15.5	412	28.0	15.0
B425R22.5-1		麻面	830	880	631	8.0	15.5	412	29.0	15.0
B255R225-1		麻面	550	720	440	6.0	12.0	432	28.0	14.0
B385R225-2		麻面	706	772	584	6.0	12.0	432	28.0	14.0
B12R22.5-1(2)	12R22.5	麻面	685	830	516	8.0	11.0	432	28.0	14.0
B13R22.5-1	12/13R22.5、315/80R22.5	麻面	704	830	532	8.0	11.0	432	28.0	14.0
B13R22.5-1(t)	12/13R22.5、315/80R22.5	麻面	704	830	532	8.0	12.0	432	26.0	14.0
B445R225-1		麻面	746	790	636	6.0	12.0	432	28.0	14.0
22.5-J-650	11R22.5	麻面	658	810	516	6.8	12.7	434	28.4	12.7
P260		碎石	600	730	472	7.2	15.8	419	26.0	15.2
P260-2		麻面	600	730	472	7.2	15.8	419	26.0	15.2
P447		碎石	660	810	492	7.2	15.8	419	26.0	15.2
P245		碎石	695	825	520	7.2	15.8	419	26.0	15.2
B1200R24-2	12.00R24	麻面	784	940	604	8.0	11.0	470	26.0	14.0
B1200R24-3	12.00R24	碎石	784	940	604	8.0	11.0	470	26.0	14.0
B255R24-1		麻面	426	600	384	5.0	8.0	454	24.0	12.7
B305R24-1		麻面	526	660	470	5.5	8.0	454	24.0	12.7
B285R245-1		麻面	630	820	490	8.0	12.0	460	28.0	14.0
B11R24.5-2	11R24.5	麻面	670	830	547	8.0	11.0	470	28.0	15.0
B11R24.5-3	11R24.5	麻面	668	860	510	8.0	12.0	460	28.0	14.0

### 注射B型子午胎硫化胶囊

#### INJECTION B TYPE RADIAL TYRE CURING BLADDER

胶囊代号	适用轮胎规格	花纹类型	胶囊尺寸					胶囊安装尺寸		
			断面周长LB (mm)	外直径DB (mm)	总高度HB (mm)	冠部厚度to (mm)	颈部厚度to' (mm)	夹缘内径dB (mm)	夹缘高度a (mm)	夹缘宽度b (mm)
Bladder code	Applied Tyre section	Vents/ Etching Type	Effective Periphery LB(mm)	Outside Diameter DB(mm)	Overall Height HB(mm)	Crown Gauge to(mm)	Neck Gauge to'(mm)	Foot ID. dB(mm)	Foot Height a(mm)	Foot Width b(mm)
B305R26-1		碎石	440	670	400	5.0	7.0	555	24.00	14.00
JTBR28-1		碎石	560	750	502	5.0	8.0	555	24.00	13.00
270-290 × 295 × 475-1		碎石	387	475	295	5.7	6.0	270/290	18.0	10.0
270-290 × 295 × 475-2		碎石	387	475	295	4.5	6.0	270/290	18.0	10.0
270-290 × 295 × 475-3		碎石	387	475	295	5.0	6.0	270/290	18.0	10.0
270-290 × 296 × 515-1		碎石	398	515	296	5.3	6	270/290	18	10
270-290 × 296 × 515-2		碎石	398	515	296	4.8	6	270/290	18	10
270-290 × 300 × 540-1		碎石	411	540	300	5.3	6	270/290	18	10
270-290 × 300 × 540-2		碎石	411	540	300	4.8	6	270/290	18	10
270-290 × 300 × 540-3		碎石	411	540	300	4.8	6	270/290	18	10
270-290 × 330 × 540-1		碎石	441	540	330	5.3	6	270/290	18	10
270-290 × 330 × 540-2		碎石	441	540	330	4.8	6	270/290	18	10
270-290 × 330 × 540-3		碎石	441	540	330	4.8	6	270/290	18	10
270-290 × 360 × 540-1		碎石	471	540	360	4.8	6	270/290	18	10
270-290 × 360 × 540-2		碎石	471	540	360	5.3	6	270/290	18	10
270-290 × 360 × 540-3		碎石	471	540	360	4.8	6	270/290	18	10
270-290 × 360 × 540-4		碎石	471	540	360	4.8	6	270/290	18	10
270-290 × 360 × 540-5		碎石	471	540	360	5.3	6	270/290	18	10
270-290 × 380 × 540		碎石	491	540	380	5.3	6	270/290	18	10
270-290 × 400 × 540		碎石	511	540	400	4.8	6	270/290	18	10
270-290 × 400 × 540-2		碎石	511	540	400	5.3	6	270/290	18	10
B17 × 214 × 560		碎石	430	560	214	4.0	9.5	170/225	24.5	11
CR15-1		碎石	463	550	254	5.0	7	276/226	24	12.9

### 注射B型子午胎硫化胶囊

#### INJECTION B TYPE RADIAL TYRE CURING BLADDER

胶囊代号	适用轮胎规格	花纹类型	胶囊尺寸					胶囊安装尺寸		
			断面周长LB (mm)	外直径DB (mm)	总高度HB (mm)	冠部厚度to (mm)	颈部厚度to' (mm)	夹缘内径dB (mm)	夹缘高度a (mm)	夹缘宽度b (mm)
Bladder code	Applied Tyre section	Vents/ Etching Type	Effective Periphery LB(mm)	Outside Diameter DB(mm)	Overall Height HB(mm)	Crown Gauge to(mm)	Neck Gauge to'(mm)	Foot ID. dB(mm)	Foot Height a(mm)	Foot Width b(mm)
HEB13-2NP-1		碎石	385	440	278	4.5	7	170/225	24	12
HEB13-2NP-2		碎石	415	460	300	4.5	7	170/225	24	12
TS2	185/65(70)R14	碎石	458	480	307	4.5	7	170/225	24	12
TS3	195/65(70)R14	碎石	476	500	321	4.5	7	170/225	24	12
HEB13/5	195/65(70)R15	碎石	499	505	337	4.5	7	170/225	24	12
TS4	195/65(70、75)R16	碎石	530	525	359	4.5	7	170/225	24	12
TS4-2		碎石	550	525	388	4.5	7	170/225	24	12
HEB20-3V1NP		碎石	718	780	515	7.5	10	290/355	28	15
HEB20-6NP		碎石	785	840	527	7.5	10	290/356	28	15
320-340 × 340 × 530BISP		碎石		530	340	5.3	7	320/340	28	12
320-340 × 370 × 530BISP		碎石		530	370	5.3	7	320/340	28	12
320-340 × 390 × 530BISP		碎石		530	390	5.3	7	320/340	28	12
320-340 × 410 × 530BISP		碎石		530	410	5.3	7	320/340	28	12
320-340 × 430 × 530BISP		碎石		530	430	5.3	7	320/340	28	12
12 × 320/340 × 345 × 560		碎石		560	345	5.3	7	320/340	28	12
12 × 320/340 × 370 × 560		碎石		560	370	5.3	7	320/340	28	12
12 × 320/340 × 390 × 560		碎石		560	390	5.3	7	320/340	28	12
12 × 320/340 × 420 × 560		碎石		560	420	5.3	7	320/340	28	12
P488		麻面	366	488	195	4.4	9	170/225	23	11
184 × 432		碎石	324	432	184	4.5	7	170/225	24	12



## 注射AB型子午胎硫化胶囊

### INJECTION AB TYPE RADIAL TYRE CURING BLADDER

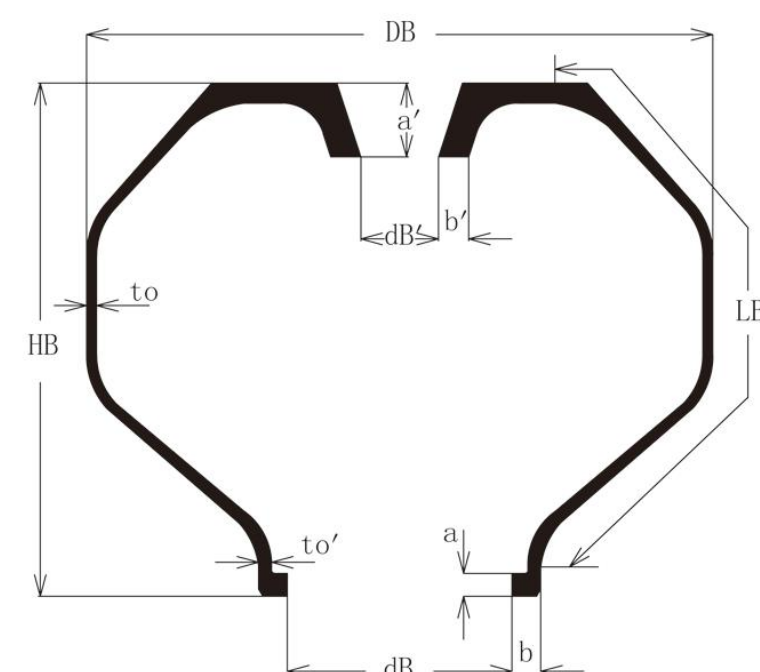

胶囊代号	适用轮胎规格	花纹类型	胶囊尺寸					胶囊安装尺寸		
			断面周长LB (mm)	外直径DB (mm)	总高度HB (mm)	冠部厚度to (mm)	颈部厚度to' (mm)	夹缘内径dB/dB' (mm)	夹缘高度a/a' (mm)	夹缘宽度b/b' (mm)
Bladder code	Applied Tyre section	Vents/Etching Type	Effective Periphery LB(mm)	Outside Diameter DB(mm)	Overall Height HB(mm)	Crown Gauge to(mm)	Neck Gauge to'(mm)	Foot ID.dB/dB' (mm)	Foot Height a(mm)	Foot Width b(mm)
AB145R12-2		碎石	344	430	240	5.5	8.0	262/98	13.5/32.5	14/20.5
AB155R13-2		碎石	368	450	245	5	8	250/145	15	15/10
AB165R13-2	165/70R13、155R13LT	碎石	380	440	330	5	9/8	240/102	14.5/40	16/11
AB165R13-1(2)	165R13 155R12LT	碎石	378	460	260	5.5	8.0	262/98	13.5/32.5	14/20.5
AB175R14-1	165(175)/70R14、185/60R14	碎石	407	470	324	5	9/8	240/102	14.5/40	16/11
AB175R14-2	175/65(70)R14	碎石	398	480	322	5	9/8	285/102	14.5/40	16/11
AB195R14-1	185/70R14、195/60R14	碎石	434	470	360	5	9/8	240/102	14.5/40	16/11
AB205R14-1	195/65R14、205/75R14	碎石	460	510	375	5	9/8	285/102	14.5/40	16/11
AB195R14-1(2)		碎石	460	486	380	5	9/8	240/102	14.5/40	16/11
AB195R15-1	195/55(60)R15	碎石	450	490	360	5	9/9	240/102	14.5/40	16/11
AB205R14-1(2)	205/75R15	碎石	498	540	396	5	9/8	285/102	14.5/40	16/11
AB235R15-2	215/225/235/75R15、255/60R16	碎石	528	560	420	5	9/8	285/102	14.5/40	16/11
AB235R15-3	225/75R15、235/75R15	碎石	546	580	412	6.3	9/8	285/102	14.5/40	16/11

## 注射AB型子午胎硫化胶囊

### INJECTION AB TYPE RADIAL TYRE CURING BLADDER

胶囊代号	适用轮胎规格	花纹类型	胶囊尺寸					胶囊安装尺寸		
			断面周长LB (mm)	外直径DB (mm)	总高度HB (mm)	冠部厚度to (mm)	颈部厚度to' (mm)	夹缘内径dB/dB' (mm)	夹缘高度a/a' (mm)	夹缘宽度b/b' (mm)
Bladder code	Applied Tyre section	Vents/Etching Type	Effective Periphery LB(mm)	Outside Diameter DB(mm)	Overall Height HB(mm)	Crown Gauge to(mm)	Neck Gauge to'(mm)	Foot ID.dB/dB' (mm)	Foot Height a(mm)	Foot Width b(mm)
AB235R16-1	215/235/85R162 25/75R16、235/80R16	碎石	572	640	393	5	9/8	285/102	14.5/40	16/11
AB235R16-2	235/80(85)R16	碎石	596	630	436	6.3	9/8	285/102	14.5/40	16/11
AB650R16-1(2)	650R16LT、650R16C	碎石	492	580	345	5	9/8	285/102	14.5/40	16/11
AB650R16-1(3)	650R16LT、650R16C	碎石	511	600	344	6.3	9/8	285/102	14.5/40	16/11
AB15/17 × 540 × 760		碎石	824	760	540	8	10/12	386/376	22/23	22/14
RIB16R20 445/65R225	1600R20、445/65R225	碎石	950	950	786	8	14/8	383/120	23/43	23/14
PD500K		碎石	620	615	389	5.0	6.9/9.5	231/152	15/21.4	14.5/10.2
PD601K		碎石	690	615	459	5.0	6.9/9.6	231/152	15/21.5	14.5/10.3
ZP414K		碎石	284	514	428	6.35	7.54/9.53	231/152	15/21.5	14.5/10.3
AB1200R20-1		碎石	752	850	548	8	14/8	383/120	23/43	23/14
AB1400R20-1		碎石	886	960	611	8	14/8	383/120	23/43	23/14
AB1400R24-1		碎石	997	1040	692	8	14/8	383/120	23/43	23/14

子午胎轮胎硫化胶囊  
RADIAL TYRE CURING BLADDER

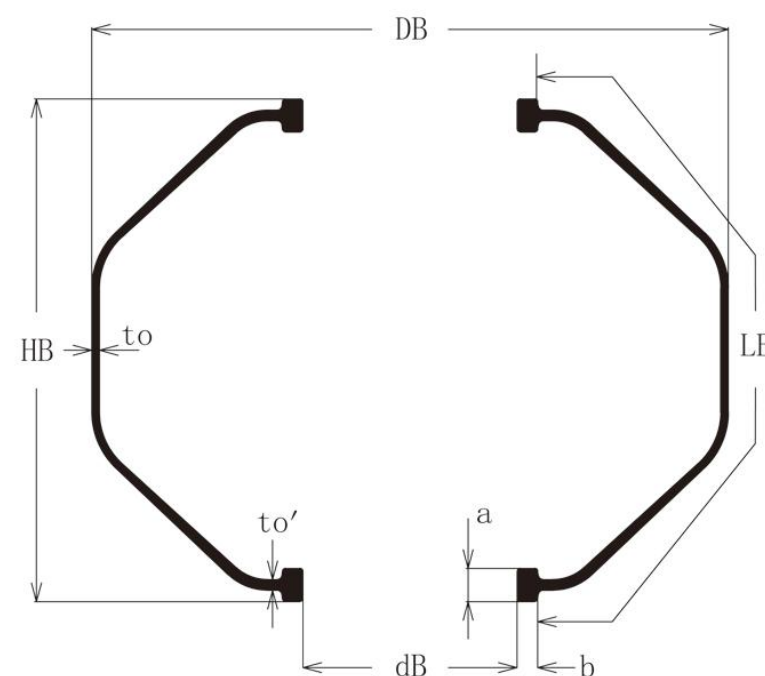

胶囊代号	适用轮胎规格	花纹类型	胶囊尺寸					胶囊安装尺寸		
			断面周长LB (mm)	外直径DB (mm)	总高度HB (mm)	冠部厚度to (mm)	颈部厚度to' (mm)	夹缘内径dB (mm)	夹缘高度a (mm)	夹缘宽度b (mm)
Bladder code	Applied Tyre section	Vents/Etching Type	Effective Periphery LB(mm)	Outside Diameter DB(mm)	Overall Height HB(mm)	Crown Gauge to(mm)	Neck Gauge to'(mm)	Foot ID. dB(mm)	Foot Height a(mm)	Foot Width b(mm)
B135R12-1	135/145R12	麻面	282	392	223	6.0	10.0	210	21.0	12.0
B145R12-1	145/165R12/13	碎石	332	450	228	5.7	7.0	224	21.0	12.0
B145R12-1(3)	145/165R12/13	碎石	332	450	228	5.7	7.0	224	21.0	12.0
B135R13-1	135/165R13	麻面	273	415	203	6.2	10.0	234	21.0	12.0
B145R13-1	135/155R13	麻面	287	421	235	4.5	10.0	234	21.0	12.0
B155R13-1	135/165R13	麻面	292	420	205	6.2	10.0	234	21.0	12.0
B165R13-1	145/175R13	碎石	316	440	235	5.0	7.5	234	21.0	12.0
B165R13-2	165/65(70)R13、155R13	碎石	346	460	260	4.5	10.0	234	21.0	12.0
B175R13-1	165/185R13	麻面	347	460	265	4.5	10.0	234	21.0	12.0
B185R14-1	155/195R14	麻面	338	460	256	4.5	10.0	260	21.0	12.0
B205R14-1	165/205R14/15	碎石	375	490	276	5.0	7.0	248	21.0	12.0
B155R15-1	155R15	碎石	364	508	265.8	4.1	6.6	285.7	21.4	11.7
B225R15-1	235/75R15/225/75R16	麻面	508	576	367	5.0	7.0	277	21.0	13.0
B185R16-1	185/215R15/16	碎石	435	550	325	5.0	7.0	277	21.0	13.0
B185R16-2	185/215R15/16	碎石	435	550	325	5.0	7.0	277	21.0	13.0
B205R16-1	205/215R16/17/18	碎石	426	438	394	6.0	7.0	304	23.3	12.8
B205R16-1	205/215R16/17/18	碎石	426	438	394	4.5	7.0	304	23.3	12.8

子午胎轮胎硫化胶囊  
RADIAL TYRE CURING BLADDER

胶囊代号	适用轮胎规格	花纹类型	胶囊尺寸					胶囊安装尺寸		
			断面周长LB (mm)	外直径DB (mm)	总高度HB (mm)	冠部厚度to (mm)	颈部厚度to' (mm)	夹缘内径dB (mm)	夹缘高度a (mm)	夹缘宽度b (mm)
Bladder code	Applied Tyre section	Vents/Etching Type	Effective Periphery LB(mm)	Outside Diameter DB(mm)	Overall Height HB(mm)	Crown Gauge to(mm)	Neck Gauge to'(mm)	Foot ID. dB(mm)	Foot Height a(mm)	Foot Width b(mm)
B205R16-2	195/65R15 205/55R16	碎石	416	508	322	4.06	9.6	285.7	21.4	11.66
B205R16-2(3)	195/65R15 205/55R16	碎石	416	508	322	6.30	9.6	285.7	21.4	11.66
B205R16-2(2)	195/65R15 205/55R16	碎石	416	508	322	4.06	9.6	285.7	21.4	11.66
B235R16-1	215/85R16/235/60R16	碎石	552	590	404	5.0	7.0	277	21.0	13.0
B265R16-1	LT245R17/LT265/75R16	麻面	570	620	389	5.0	7.0	277	21.0	13.0
B825R16-1	8.25R16	碎石	550	600	440	7.0	10.0	300	24.0	12.0
B225R17-1	225/50R17	碎石	424	520.7	368	4.5	9.551	336.55	21.88	11.66
B225R17-1(2)	225/55R17	碎石	427	520.7	366	4.5	9.551	336.55	21.88	11.66
B225R17-1(3)	225/55R17	碎石	427	520.7	366	5.5	9.551	336.55	21.88	11.66
B235R18-1	225/40R18	碎石	390	490	338	4.5	9.551	336.55	21.88	11.66
B255R18-1	255/265/35R18、235/245/35R19	麻面	414	500	368	6.0	8.0	353	24.0	12.9
B255R18-2	255/45R18、235/50R18	麻面	450	544	390	6.0	8.0	353	24.0	12.9
B215R19-1	215/225/35R19	麻面	385	500	350	6.0	8.0	378	24.0	12.7
B245R19.5-1	24.5/70R19.5	碎石	548	648	438	7.0	11.0	340	26.0	14.0
B225R20-1	225/35R20	麻面	378	528	338	6.0	8.0	403	24.0	12.7
B825R20-1	8.25R20	碎石	574	790	342	7.0	12.0	378	24.0	14.0
B825R20-2	8.25R20	麻面	574	790	342	8.0	12.0	378	24.0	14.0
B900R20-1	9.00/10.00R20	碎石	651	760	500	9.5	12.0	380	24.0	14.0
B900R20-2	9.00/10.00R20	麻面	651	760	500	8.0	12.0	380	24.0	14.0
B900R20-2(2)	9.00/10.00R20	麻面	651	760	500	8.0	12.0	380	26.7	14.0
B1000R20-1	9.00/10.00R20	碎石	651	815	452	7.6	12.0	380	24.0	14.0
B1000R20-2	9.00/10.00R20	麻面	651	815	452	8.0	12.0	380	24.0	14.0

子午胎硫化胶囊  
RADIAL TYRE CURING BLADDER

胶囊代号	适用轮胎规格	花纹类型	胶囊尺寸					胶囊安装尺寸		
			断面周长LB (mm)	外直径DB (mm)	总高度HB (mm)	冠部厚度to (mm)	颈部厚度to' (mm)	夹缘内径dB (mm)	夹缘高度a (mm)	夹缘宽度b (mm)
Bladder code	Applied Tyre section	Vents/Etching Type	Effective Periphery LB(mm)	Outside Diameter DB(mm)	Overall Height HB(mm)	Crown Gauge to(mm)	Neck Gauge to'(mm)	Foot ID. dB(mm)	Foot Height a(mm)	Foot Width b(mm)
B1000R20-8	9.00/10.00R20	麻面	651	815	452	9.0	12.0	380	24.0	14.0
B20/635	9.00/10.00-20	麻面	635	571.5	587	9.5	12.7	384.2	28.4	12.7
B3	10.00R20 11.00R20	麻面	693	571.5	644	9.5	12.7	384.2	28.4	12.7
B1200R20-1	11.00/12.00R20	碎石	740	865	500	7.7	12.0	380	24.0	14.0
B1200R20-1(2)	11.00/12.00R20	碎石	740	865	500	7.7	12.0	380	24.0	14.0
B1200R20-1(3)	11.00/12.00R20	碎石	740	865	500	9.2	12.0	380	24/22	14.0
B1200R20-1(4)	11.00/12.00R20	碎石	740	865	500	9.2	12.0	380	24/22	14.0
B1200R20-2	11.00/12.00R20	麻面	740	865	500	8.0	12.0	380	24.0	14.0
B1200R20-2(2)	11.00/12.00R20	麻面	740	865	500	8.0	12.0	380	24.0	14.0
B1200R20-2(4)	11.00/12.00R20	麻面	740	865	500	8.0	12.0	380	24.0	14.0
B1200R20-8	11.00/12.00R20	麻面	740	865	500	9.0	12.0	380	24.0	14.0
B1200R20-11	11.00/12.00R20	碎石	740	865	500	7.6	12.0	380	24.0	14.0
B1400R20-1	1400R20/385(425)/65R22.5	碎石	840	830	684	8.0	12.0	380	24.0	14.0
B1400R20-1(2)	1400R20/385(425)/65R22.5	碎石	840	830	684	8.0	12.0	380	24.0	14.0
B295R22-1	295/45R22	麻面	525	627	278	6.2	9.5	419	21.4	11.7
B385R22.5-1	385/55(65)R22.5	碎石	758	680	670	9.0	12.0	380	24.0	14.0
B1200R24-1	12.00R24	麻面	784	940	604	8.0	11.0	470	26.0	14.0
B11R24.5-1	11.00R24.5/12.00R24.5	碎石	670	830	547	8.0	11.0	470	28.0	15.0

子午胎硫化胶囊  
RADIAL TYRE CURING BLADDER

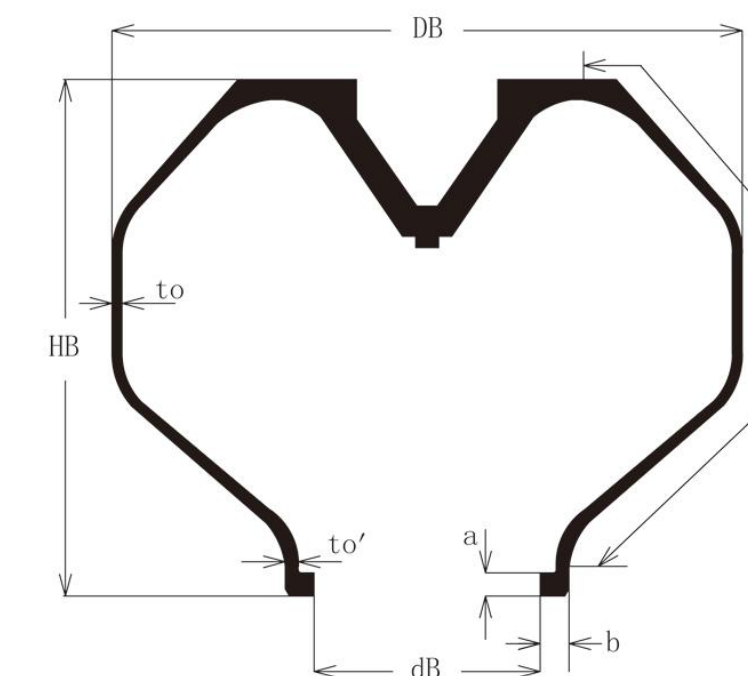

胶囊代号	适用轮胎规格	花纹类型	胶囊尺寸					胶囊安装尺寸		
			断面周长LB (mm)	外直径DB (mm)	总高度HB (mm)	冠部厚度to (mm)	颈部厚度to' (mm)	夹缘内径dB (mm)	夹缘高度a (mm)	夹缘宽度b (mm)
Bladder code	Applied Tyre section	Vents/Etching Type	Effective Periphery LB(mm)	Outside Diameter DB(mm)	Overall Height HB(mm)	Crown Gauge to(mm)	Neck Gauge to'(mm)	Foot ID. dB(mm)	Foot Height a(mm)	Foot Width b(mm)
A135R12-1	135/145R12	麻面	321	450	255	4.5	8.0	261	12.5	14.5
A145R12-1	145/155R12	碎石	344	460	240	6.0	8.0	261	12.5	13.0
A155R13-1	145/175R13/14	麻面	376	470	304	4.5	8.0	261	12.5	14.5
A165R13-1	155/185R13/14	麻面	420	510	304	4.5	8.0	261	12.5	14.5
A195R15-1	165/195R15/16	碎石	446	540	304	4.5	8.0	261	12.5	14.5
A205R15-1	185/215R15/16	麻面	485	570	304	4.5	8.0	261	12.5	14.5
A235R16-1	235R16	碎石	497	590	342	5.7	8.2	310	12.5	16.0
A215R17-1	215/205/40R17	麻面	466	483	365	5.5	9.0	285	14.5	15.0
A215R18-1	215R18	麻面	489	483	379	5.5	9.0	285	14.5	15.0

## 子午胎硫化胶囊 RADIAL TYRE CURING BLADDER

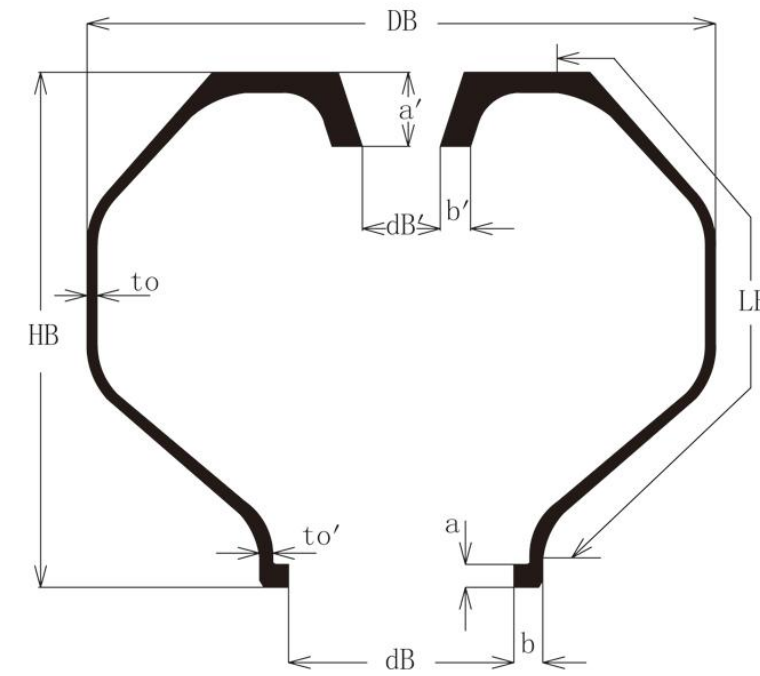

胶囊代号	适用轮胎规格	花纹类型	胶囊尺寸					胶囊安装尺寸		
			断面周长LB (mm)	外直径DB (mm)	总高度HB (mm)	冠部厚度to (mm)	颈部厚度to' (mm)	夹缘内径dB (mm)	夹缘高度a (mm)	夹缘宽度b (mm)
Bladder code	Applied Tyre section	Vents/ Etching Type	Effective Periphery LB(mm)	Outside Diameter DB(mm)	Overall Height HB(mm)	Crown Gauge to(mm)	Neck Gauge to'(mm)	Foot ID. dB(mm)	Foot Height a(mm)	Foot Width b(mm)
AB155R13-1	165R13 155R12LT	麻面	365	480	280	5.5	7.5	262/98	13.5/32.5	14/20.5
AB165R13-1	165R13 155R12LT	碎石	378	460	260	5.5	8.0	262/98	13.5/32.5	14/20.5
AB185R14-1	155/185R13/14	麻面	394	470	275	5.5	6.5	262/102	13.5/41	14/13.5
AB185R15-1	165/185R14/15	碎石	449	500	315	5.5	6.5	262/102	13.5/41	14/13.5
AB185R16-1	185/205R15/16	麻面	536	560	355	5.5	6.5	262/102	13.5/41	14/13.5
AB1000R20-1	9.00/10.00R20	麻面	687	864	450	9.5	13.5	408.8/50	20/86.8	23.6/46

## B型斜交胎硫化胶囊 B TYRE BLAS TYRE CURING BLADDER

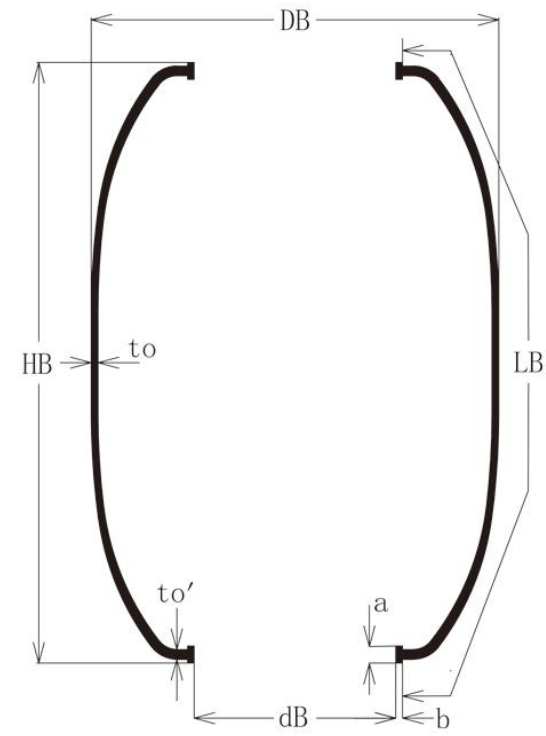

胶囊代号	适用轮胎规格	花纹类型	胶囊尺寸					胶囊安装尺寸		
			断面周长LB (mm)	外直径DB (mm)	总高度HB (mm)	冠部厚度to (mm)	颈部厚度to' (mm)	夹缘内径dB (mm)	夹缘高度a (mm)	夹缘宽度b (mm)
Bladder code	Applied Tyre section	Vents/ Etching Type	Effective Periphery LB(mm)	Outside Diameter DB(mm)	Overall Height HB(mm)	Crown Gauge to(mm)	Neck Gauge to'(mm)	Foot ID. dB(mm)	Foot Height a(mm)	Foot Width b(mm)
B9×350-4-1	9×3.50-4	碎石	173	128	156	5.0	7.0	68	16.0	8.0
B350-4-1	3.50/4.10-4	碎石	188	135	166	5.0	7.0	68	16.0	8.0
B410-4-1	3.50/4.10-4	碎石	230	116	202	5.0	7.0	42	16.0	7.0
B11×400-5-1	11×4-5、10×4.5-5	碎石	218	140	200	6.0	6.0	67	16.0	6.0
B11×710-5-1	11×7.10-5	碎石	311	145	284	5.0	6.0	67	16.0	6.0
B4501	4.5-5	碎石	280	145	250	5.0	6.0	67	16.0	6.0
B13×500-6-1	13×5.00-6	碎石	260	160	238	7.5	8.5	84	19.0	9.0
B13×500-6-1(2)	13×5.00-6	碎石	260	160	238	7.5	8.5	84	19.0	9.0
B13×600-6-1	13×6.00-6 145-6	麻面	310	165	288	7.5	8.5	84	19.0	9.0
B13×650-6-1	13×6.50-6 5×6.00-6	碎石	340	165	312	7.5	8.5	84	19.0	9.0
B13×650-6-2	13×6.50-6 5×6.00-6	碎石	340	165	312	7.5	8.5	84	19.0	9.0
B300-8	3.00-8									
B16×8-7-1	16X8-7	碎石	348	190	320	6.0	8.0	96	15.0	8.0
B16×8-7-2	16X8-7	碎石	372	190	334	6.0	8.0	96	15.0	8.0
B400-8-1	4.00-8	碎石	288	205	266	6.0	6.5	116	22.0	11.0
B16×7-8-1	16×7-8、16×6-8	碎石	358	230	320	6.0	9.0	114	22.0	11.5
B18×850-8-1	18×8.50-8 18×9.50-8	碎石	440	220	410	8.5	8.5	114	22.0	12.0

## B型斜交胎硫化胶囊

### B TYRE BLAS TYRE CURING BLADDER

胶囊代号	适用轮胎规格	花纹类型	胶囊尺寸					胶囊安装尺寸		
			断面周长LB (mm)	外直径DB (mm)	总高度HB (mm)	冠部厚度to (mm)	颈部厚度to' (mm)	夹缘内径dB (mm)	夹缘高度a (mm)	夹缘宽度b (mm)
Bladder code	Applied Tyre section	Vents/ Etching Type	Effective Periphery LB(mm)	Outside Diameter DB(mm)	Overall Height HB(mm)	Crown Gauge to(mm)	Neck Gauge to'(mm)	Foot ID. dB(mm)	Foot Height a(mm)	Foot Width b(mm)
B300		碎石	400	220	368	6.0	8.5	114	22.0	12.0
B20 × 10-9-1	20 × 10-9、20 × 11-9	碎石	490	290	450	6.0	9.0	165	18.0	10.0
B14 × 2.125-10-1	14 × 2.125-10	碎石	150	260	118	5.0	7.0	183	14.0	9.0
B300-10-1	3.0-10	碎石	230	245	208	5.0	7.0	183	14.0	9.0
B350-10-1	3.50-10	碎石	270	246	250	6.0	6.0	183	15.0	6.0
B22 × 7-10-1	21 (22/23) × 7-10	碎石	384	290	339	6.0	9.0	165	22.0	8.0
B22 × 11-10-1	22 × 11-10	碎石	530	320	482	8.0	9.0	166	24.0	12.0
B20 × 14-10-1	20 × 14-10	碎石	550	296	475	6.0	7.0	157	15.0	10.0
B10F		麻面	195	284	178	5.5	7.0	190	17.0	11.0
B450-12-1	4.5-12	碎石	300	310	274	7.0	9.0	228	18.0	9.0
B500-12-1	5.0-12	碎石	328	310	304	7.0	9.0	228	18.0	9.0
B500-12-1	5.0-12	碎石	328	310	304	7.0	9.0	228	18.0	9.0
B600-12-1	6.0-12	碎石	342	320	320	7.0	9.0	228	18.0	9.0
B24 × 8-12-1	24X8-12	碎石	443	330	410	8.0	11.0	220	21.0	12.5
B25 × 11-12-1	25X11-12、25 × 10-12	碎石	548	360	502	6.0	9.0	220	22.0	12.5
B25 × 12-12-1	25X12-12	碎石	592	360	546	6.0	9.0	220	22.0	12.5
B275-14-1	山地/自行车/摩托车	麻面	191	365	164	5.0	7.0	280	16.0	8.0
B1500-15-1	15.00-15	麻面	628	500	580	7	10	310	24	12
B1600-15-1	16.00-15	碎石	744	500	698	7.0	10.0	310	24.0	12.0
B250-16-1	山地/自行车/摩托车	麻面	133	410	109	5.0	7.0	340	16.0	8.0
B650-16-1	6.50-16	碎石	446	420	410	8.2	10.0	260	24.0	12.5
B650-16-2	6.50-16	麻面	446	420	410	8.2	10.0	260	24.0	12.5
B700-16-1	7.00-16	麻面	430	445	402	7.5	8.5	310	23.5	11.5
B750-16-1	7.50-16	碎石	494	490	440	8.0	8.0	310	24.0	12.5

## B型斜交胎硫化胶囊

### B TYRE BLAS TYRE CURING BLADDER

胶囊代号	适用轮胎规格	花纹类型	胶囊尺寸					胶囊安装尺寸		
			断面周长LB (mm)	外直径DB (mm)	总高度HB (mm)	冠部厚度to (mm)	颈部厚度to' (mm)	夹缘内径dB (mm)	夹缘高度a (mm)	夹缘宽度b (mm)
Bladder code	Applied Tyre section	Vents/ Etching Type	Effective Periphery LB(mm)	Outside Diameter DB(mm)	Overall Height HB(mm)	Crown Gauge to(mm)	Neck Gauge to'(mm)	Foot ID. dB(mm)	Foot Height a(mm)	Foot Width b(mm)
B750-16-2	7.50-16	麻面	494	490	440	8.0	8.0	310	24.0	12.5
B11L-16-1	11L-16	麻面	550	485	498	10.0	12.0	320	26.0	14.0
B10-16.5-1	10-16.5	麻面	525	445	464.9	7.0	9.1	277	21.8	12.7
B400-17-1	山地/自行车/摩托车	麻面	206	472	164	5.0	7.0	360	16.0	8.0
B300-18-1	2.75/3.00-18	麻面	188	455	159	5.0	6.0	385	13.0	4.0
B325-19-1	3.25-19	碎石	241	470	220	5.0	6.5	408	13.5	9.0
B825-20-1	8.25-20	碎石	558	500	518	9.5	13.0	360	27.5	14.5
B900-20-1	9.00-20	碎石	642	608	568	9.5	12.0	360	28.0	14.0
B900-20-1(JG)	16/70-20	碎石	782	608	708	9.5	12.0	360	28.0	14.0
B900-20-2	9.00-20	麻面	642	608	568	9.5	12.0	360	28.0	14.0
B900-20-3	9.00-20	麻面	652	580	600	10.0	12.5	360	28.0	14.0
B1000-20-1	9.00/10.00-20	碎石	649	602	584	9.2	12.0	380	28.0	14.0
B1000-20-2	9.00/10.00-20	碎石	649	602	584	9.2	12.0	380	28.0	14.0
B1100-20-1	11.00-20	碎石	706	634	630	9.5	12.0	380	28.0	14.0
B1100-20-2	11.00-20	麻面	704	630	626	11.5	12.5	380	28.0	14.0
B1400-20-1	14.00-20	碎石	910	660	846	9.0	14.5	380	30.0	15.0
B1600-20-1	16.00-20	碎石	990	700	904	8.0	12.0	380	28.0	14.0
B350-21-1	山地/自行车/摩托车	麻面	200	570	162	5	7	460	16	8
B2100-21-1	21.00-21	光面	901	740	756	10.0	13.0	384	28.0	15.0
B11-225-1	11-22.5	碎石	692	630	610	11.5	13.5	370	28.0	13.0
B1200-24-1	12.00-24	碎石	732	730	650	10.5	14.0	470	28.0	14.0
B1200-24-2	12.00-24	碎石	732	730	650	10.5	14.0	470	28.0	14.0
B1200-24-3	12.00-24	碎石	780	714	708	10.0	14.0	470	28.0	14.0
B1200-24-3(2)	12.00-24	碎石	780	714	708	15.0	14.0	470	28.0	14.0
B175L-24-1	16.9L/17.5L-24	碎石	820	665	733	10.0	15.0	465	29.0	15.0
B195L-24-1	19.5L-24	碎石	920	695	819	10.0	15.0	465	29.0	15.0

## B型斜交胎硫化胶囊

### B TYRE BLAS TYRE CURING BLADDER

胶囊代号	适用轮胎规格	花纹类型	胶囊尺寸					胶囊安装尺寸		
			断面周长LB (mm)	外直径DB (mm)	总高度HB (mm)	冠部厚度to (mm)	颈部厚度to' (mm)	夹缘内径dB (mm)	夹缘高度a (mm)	夹缘宽度b (mm)
Bladder code	Applied Tyre section	Vents/ Etching Type	Effective Periphery LB(mm)	Outside Diameter DB(mm)	Overall Height HB(mm)	Crown Gauge to(mm)	Neck Gauge to'(mm)	Foot ID. dB(mm)	Foot Height a(mm)	Foot Width b(mm)
B175-25-1	17.5-25	碎石	858	770	766	10.5	14.0	470	28.0	14.0
B175-25-2	17.5-25	碎石	858	770	766	12.0	14.0	470	28.0	14.0
B175-25-3	17.5-25	碎石	876	714	802	16.0	18.0	470	36.0	15.5
B175-25-4	17.5-25	碎石	924	714	850	9.5	13.0	470	28.0	12.5
B175-25-4(2)	17.5-25	碎石	924	714	850	13.0	13.0	470	28.0	12.5
B205-25-1	20.5-25	碎石	996	880	865	15.5	18.0	470	36.0	18.0
B205-25-2	20.5-25	碎石	996	880	865	15.5	18.0	470	36.0	18.0
B205-25-3	20.5-25	碎石	1097	830	990	15.0	22.5	470	38.0	15.5
B235-25-1	23.5-25	碎石	1025	890	876	15.5	18.0	470	36.0	15.0
B235-25-2	23.5-25	碎石	1213	830	1100	14.0	22.5	470	36.0	14.5
B235-25-2(3)	23.5-25	碎石	1213	830	1100	14.0	22.5	470	36.0	14.5
B235-25-4	23.5-25	碎石	1213	830	1100	14.0	22.5	470	36.0	14.5
B265-25-1	26.5-25	碎石	1460	890	1350	14.0	23.0	470	36.0	15.5
B265-25-2	26.5-25	碎石	1356	890	1230	14.0	23.0	470	36.0	15.5
B295-25-1	29.5-25	碎石	1520	916	1402	14.0	23.5	470	38.0	15.0
BOM-Z-2203	山地/自行车/摩托车	碎石	148	569	126	4.5	5.5	498	14.0	8.3
BOM-Z-622-02	山地/自行车/摩托车	碎石	80	620	59	3.5	5.0	565	14.0	8.0
BOM-Z-622-02	山地/自行车/摩托车	碎石	80	620	59	4.5	5	565	14	8
BOM-Z-622-02(2)	山地/自行车/摩托车	碎石	80	620	59	3.5	5.0	565	14.0	8.0
BOM-Z-622-02(3)	山地/自行车/摩托车	碎石	80	620	59	3.5	5.0	565	14.0	8.0
BOM-Z-622-04	山地/自行车/摩托车	碎石	110	625	93	3.8	5.5	555	14.5	9.0
BOM-Z-622-06	山地/自行车/摩托车	碎石	143	632	119	3.8	5.5	555	14.5	9.0
BOM-Z-630-02	山地/自行车/摩托车	碎石	84	627	64	3.5	5.0	565	14.0	8.0
BOM-Z-630-03	山地/自行车/摩托车	碎石	98	627	76	3.5	5.0	565	14.0	8.0
BOM-Z-584	山地/自行车/摩托车	碎石	152	594	126.5	4.5	5.5	520	14.0	8.1
BOM507-05	山地/自行车/摩托车	碎石	128	520	104	3.5	5.5	445	14.5	8.0
A650-16-1	6.50-16	碎石	540	440	470	8.5	9.5	310	12.5	17.5
A750-16-1	7.50-16	碎石	545	472	470	9.0	11.0	310	13.0	19.0

## 巨型子午胎硫化胶囊

### OTR RADIAL TYRE CURING BLADDER

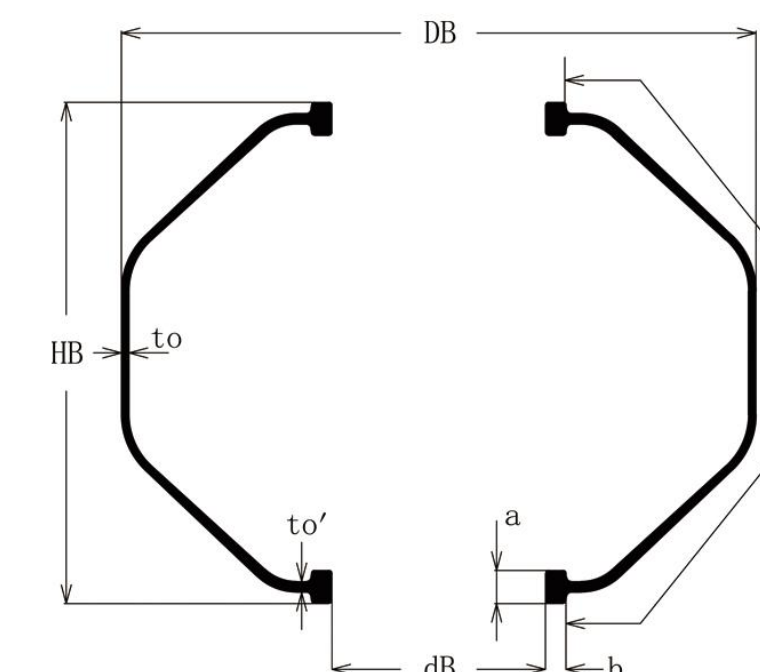

胶囊代号	适用轮胎规格	花纹类型	胶囊尺寸					胶囊安装尺寸		
			断面周长LB (mm)	外直径DB (mm)	总高度HB (mm)	冠部厚度to (mm)	颈部厚度to' (mm)	夹缘内径dB (mm)	夹缘高度a (mm)	夹缘宽度b (mm)
Bladder code	Applied Tyre section	Vents/ Etching Type	Effective Periphery LB(mm)	Outside Diameter DB(mm)	Overall Height HB(mm)	Crown Gauge to(mm)	Neck Gauge to'(mm)	Foot ID. dB(mm)	Foot Height a(mm)	Foot Width b(mm)
B175R25-1	175R25	碎石	858	1025	632	9.0	16.0	512	36.0	16.0
B205R25-1	20.5R25	碎石	981	1080	730	11.0	16.0	512	36.0	16.0
B235R25-1	23.5R25	碎石	1075	1140	760	11.0	16.0	512	36.0	16.0
B265R25-1	26.5R25	碎石	1298	1180	1040	11.0	16.0	512	36.0	16.0
B295R25-1	29.5R25	碎石	1450	1330	1110	11.0	16.0	512	36.0	16.0
B33.25R29-1	33.25R29	碎石	1655	1540	1194	12.0	22.23	571.5	38.1	15.24
B1800R33-1	18.00R33	碎石	1122	1340	786	12.0	22.23	647.7	38.1	15.24
B35R33-1	35/65R33	碎石	1546	1420	1280	12.0	22.23	647.7	38.1	15.24
B2400R35-1	24.00R35	碎石	1478	1550	1066	12.0	22.20	647.7	38.1	15.24
B2700R49-1	27.00R49	碎石	1700	2060	1106	13.0	22.23	952.5	38.1	15.24
B3300R51-1	33.00R51	碎石	2050	2200	1456	13.0	22.23	952.5	38.1	15.24
B3600R51-1	36.00R51	碎石	2256	2450	1430	13.0	22.23	952.5	38.1	15.24
B3700R57-1	37.00R57	碎石	2300	2540	1640	13.0	22.23	1135	38.1	15.24
B4000R57-1	40.00R57	碎石	2800	2600	2126	13.0	22.23	1135	38.1	15.24
B4000R57-2	40.00R57	碎石	2586	2765	2000	20.0	26.00	1310	40.0	20.00
B50R57-1	50.00/80R57	碎石	2700	2760	1936	13.0	22.23	1135	38.1	15.24
B59R63-1	59/85R63	碎石	2856	2765	2270	20.0	26.00	1310	40.0	20.00

## 巨型斜交胎硫化胶囊

### OTR BIAS TYRE CURING BLADDER

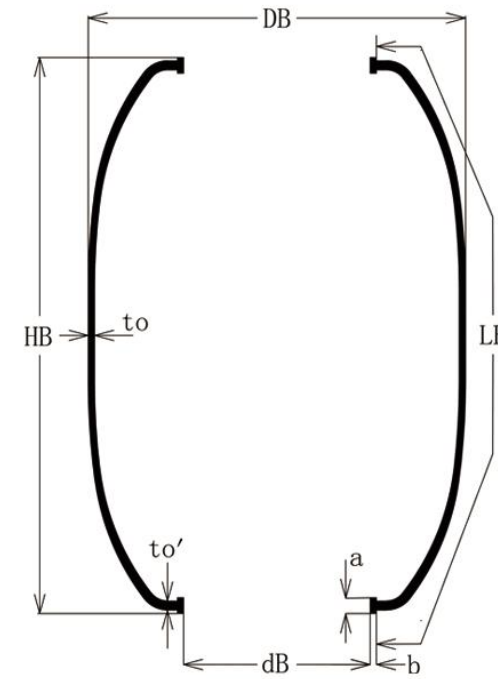

胶囊代号	适用轮胎规格	花纹类型	胶囊尺寸					胶囊安装尺寸		
			断面周长LB (mm)	外直径DB (mm)	总高度HB (mm)	冠部厚度to (mm)	颈部厚度to' (mm)	夹缘内径dB (mm)	夹缘高度a (mm)	夹缘宽度b (mm)
Bladder code	Applied Tyre section	Vents/ Etching Type	Effective Periphery LB(mm)	Outside Diameter DB(mm)	Overall Height HB(mm)	Crown Gauge to(mm)	Neck Gauge to'(mm)	Foot ID. dB(mm)	Foot Height a(mm)	Foot Width b(mm)
B29.5-29-1	29.5-29	碎石	1583	1111.25	1464	15.00	22.23	571.5	38.1	15.24
B1800-33-1	18.00-33	碎石	1165	958.85	1092	15.88	22.23	647.7	38.1	15.24
B1800-33-1(JG)	2100-35	碎石	1345	959.85	1272	15.88	22.23	647.7	38.1	15.24
B35-33-1	35/65-33	碎石	1688	1085.9	1590	15.00	22.23	647.7	38.1	15.24
B2400-35-1	24.00-35	碎石	1418	1016	1336	15.88	22.23	647.7	38.1	15.24
B37.25-35-1	37.25-35	碎石	1849	1200	1736	15.00	22.23	647.7	38.1	15.24
B45-45-1	45/65-45	碎石	2140	1364	2054	15.00	22.23	901.7	38.1	15.24
B2400-49-1	24.00-49	碎石	1342	1193.8	1277	15.00	22.23	952.5	38.1	15.24
B2700-49-1	27.00-49/30.00-51	碎石	1676	1371.6	1590	15.88	22.23	952.5	38.1	15.24
B3600-51-1	33.00-51/36.00-51	碎石	2079	1384.3	1996	15.88	22.23	952.5	38.1	15.24
B37.00-57-1	37.00-57	碎石	2280	1800.0	2080	15.00	22.23	1135	38.1	15.24
B4000-57-1	40.00-57	碎石	2650	1800	2460	15.0	22.2	1135	38.1	15.2
B53-63-1	53/80-63	碎石	2820	2000	2588	15.0	22.2	1135	38.1	15.2

## 农用胎硫化胶囊

### AGRICULTURAL TYRE CURING BLADDER

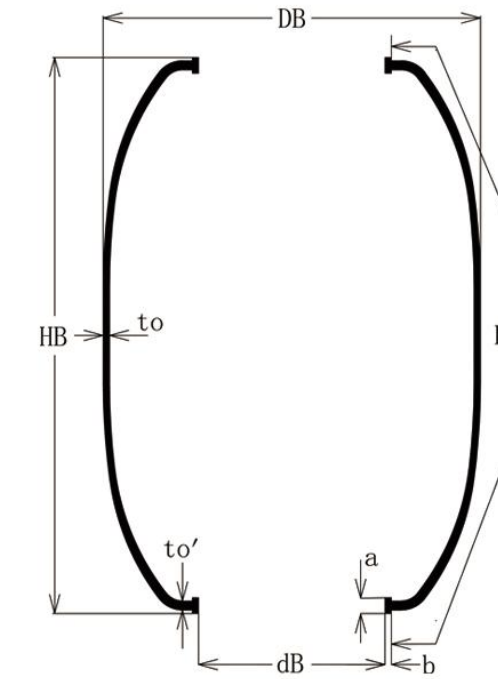

胶囊代号	适用轮胎规格	花纹类型	胶囊尺寸					胶囊安装尺寸		
			断面周长LB (mm)	外直径DB (mm)	总高度HB (mm)	冠部厚度to (mm)	颈部厚度to' (mm)	夹缘内径dB (mm)	夹缘高度a (mm)	夹缘宽度b (mm)
Bladder code	Applied Tyre section	Vents/ Etching Type	Effective Periphery LB(mm)	Outside Diameter DB(mm)	Overall Height HB(mm)	Crown Gauge to(mm)	Neck Gauge to'(mm)	Foot ID. dB(mm)	Foot Height a(mm)	Foot Width b(mm)
B9340		碎石	902	584	850	11	15.00	305	31.8	12.70
B9341		碎石	1002	584	950	11	15.00	305	31.8	12.70
B8.3-24-1	8.3-24	碎石	450	660	380	12	14.00	470	28.0	14.00
B11.2-24-1	9.5-24/11.2-24	碎石	540	660	460	12	14.00	470	28.0	14.00
B11-28-1		碎石	628	724	560	12	12.00	530	28.0	14.00
B14.9-30-1	14.9-30	碎石	765	890	662	12.0	16	600	29	14.00
B14.9-30-1(2)	14.9-30	碎石	765	890	662	13.0	16	600	29	14.00
B16.9-30-1	16.9-30	碎石	860	900	758	10	16.00	600	29.0	14.00
B18.4-30-1	18.4-30	碎石	930	900	828	10	16.00	600	29.0	14.00
B11-32-1	11-32	碎石	624	900	551	12.0	12.7	678	29	13.5
B16.9-34-1	16.9-34	碎石	842	900	756	10	15.30	716	30.0	16.00
B18.4-34-1	18.4-34	碎石	914	916	824	10	15.50	716	30.0	16.00
B12.4-38-1	11.2-38 12.4-38	碎石	687	1020	634	10	11.20	827	25.0	12.50
B18.4-38-1	18.4/15-38	碎石	910	1020	838	10	13.50	827	25.0	12.00
BK325		碎石	695	1120	596.4	15	12.50	825	23.5	14.00
BK327		碎石	840	1120	741.4	15	12.50	825	23.5	14.00
BK329		碎石	945	1120	846.4	15	12.50	825	23.5	14.00
B18.4-42-1	18.4-42	碎石	975	1120	904	10	16.00	850	36.0	15.00
B4246		碎石	1046	1030	955	13	16	843	33.8	16.00
BK4650		碎石	1101	1200	1020	12.5	14	975	34	16

## 空气弹簧硫化胶囊 AIR SPRINT CURING BLADDER

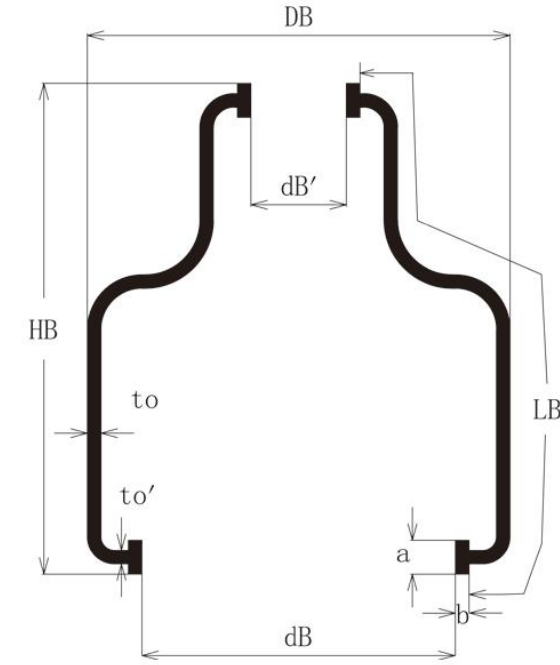

胶囊代号	适用轮胎规格	花纹类型	胶囊尺寸					胶囊安装尺寸		
			断面周长LB (mm)	外直径DB (mm)	总高度HB (mm)	冠部厚度to (mm)	颈部厚度to' (mm)	夹缘内径dB/dB' (mm)	夹缘高度a/a' (mm)	夹缘宽度b/b' (mm)
Bladder code	Applied Tyre section	Vents/Etching Type	Effective Periphery LB(mm)	Outside Diameter DB(mm)	Overall Height HB(mm)	Crown Gauge to(mm)	Neck Gauge to'(mm)	Foot ID. dB/dB'(mm)	Foot Height a(mm)	Foot Width b(mm)
C464		麻面	368	380	254	6	7	110/120	28	10
C450		麻面	509	460	434	8	12	140/360	28	14
C510A		碎石	618	520	522	9	12	140/381	28	14
C510E		碎石	570	465	500	6	12	140/340	28	14
C550		麻面	414	520	299	5	7	248	21	12
C580-3	580、580-3	碎石	436	490	350	6	10	260	12.5	24
CK406	CK406	碎石	444	568	374	5	7	368/380	28	10
B769N		碎石	375	165	348	5	8.5	84	19	9
C430		碎石	470	360	436	5	11	200	21	12.5
C580-3-2		碎石	438	483	330	6	10	230	24	12.5
C530-EMU		碎石	610	520	494	9	12	140/340	28	14
C530-1	530-1	碎石	481	405	428	6	12	140/330	28	14
C525		碎石	408	360	352	6	11	210	21	12.5
C630C	630C	碎石	426	500	389	5	7	368/380	28	10
C400B		碎石	393	370	342	5	12	120/280	28	14
C560		碎石	448	400	396	6	12	145/280	27	10
C644N		碎石	403	135	380	7.5	7	70	15	8
C550B		碎石	443	430	375	6	12	140/330	28	14
C500D		碎石	444	405	390	6	12	140/330	28	14
C470		碎石	424	290	288	6	9	150	22	12
C600C		碎石	408	530	349	6	10	310/400	24	12
LB2		碎石	355	207	356	6	9	113	27	9.5
1E25		碎石	387	180	349	6	7.5	90	16.5	7
1DK32		碎石	486	223	445	6	8.5	132	17.5	7

## 垫带 FLAP

可根据客户要求 在气门嘴部位安装铁片  
We can install metal plates in the valve site according to customers' requirements.



规格 specification	主要部位尺寸 ≥ mm The main dimension ≥ mm			重量 ≥ (Kg) weight ≥ (Kg)
	展平宽 section width	中部厚 middle thickness	外周长 outside circumference	
9.00/8.25-16	180	3.4-3.6	1290	1.15
9.00/8.25-20	181	5.3	1590	1.53
9.75-18	151	4	1465	1.26
9.00/10.00-20	215	5.8-6.2	1638	2.3
11.00/12.00-20	222	6.5-7.3	1658	2.78
11.00-22	227	6.9	1820	2.73
11.00-18	228	6.3-6.5	1464	2.49
12.00-24	236	6.6-7.3	1934	4.03
14.00-20	235	7.3-7.8	1645	2.73
14.00-24	325	7.2	1962	4.03
16/70-20	325	7.3	1660	4.5
16/70-24	323	8.4	1975	5.13
16/15.5-20	288	8.4	1655	4.7
13.00-25	221	9.0-9.2	1968	4.5
17.5-25	323	7.6-7.9	2010	6.5
20.5-25	420	8.7-8.9	2017	8.5
23.5-25	504	8.8-9.1	2020	10.58